

SPECIFICATIONS

BLOOM SINK MIXER

Adp

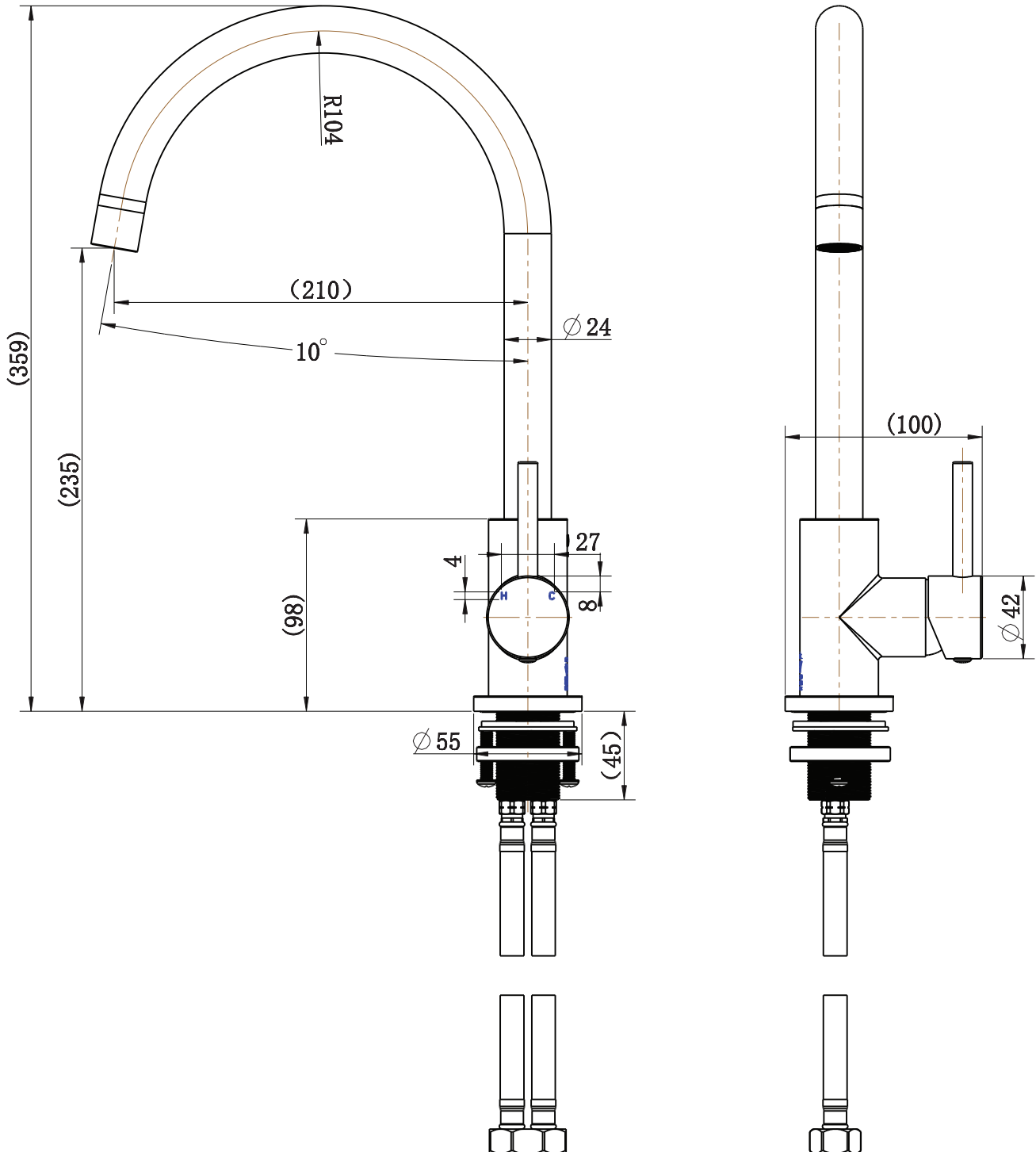

JTAPKBLMCP
JTAPKBLMBA
JTAPKBLMNK
JTAPKBLMBB



Water supply requirements

Not recommended for gravity fed water systems or water tanks.

Working Pressure: 350 - 500kpa (including cold and hot water pressure)
Maximum Pressure: 73psi / 500kpa
Temperature Rating: 5°C - 65°C (must not exceed 70°C)

Installation should comply with Australian standard AS/NZS 3500 or relevant local authority requirements.